



## DESCRIPTION

The SM30KPAN Series are high-powered surface mount transient voltage suppression components designed to protect equipment and systems from the damaging effects of high voltage spikes. The surface mount package configuration provides a lower profile compared to legacy axial lead package configurations.

These devices provide 30,000 Watts of peak pulse power dissipation for an 10/1000 $\mu$ s waveform. Applications include AC and DC power line protection, terrestrial base station protection as well as module lightning protection.

## FEATURES

- **RTCA DO-160G COMPLIANT PRODUCT**
- Compatible with IEC 61000-4-5 (Surge): 48A, 8/20 $\mu$ s - L3(Line-Ground), L4(Line-Line) & L1 (Power)
- 30,000 Watts Peak Pulse Power per Line (tp = 10/1000 $\mu$ s)
- Unidirectional and Bidirectional Configurations
- Easy Mounting to Printed Circuit Board
- Available in Multiple Voltages
- tClamping (0V to V<sub>(BR)</sub> Min) < 100ps, Theoretical for Unidirectional and 5ns for Bidirectional
- RoHS Complaint (Exemption #7)

## APPLICATIONS

- Relay Drives
- Motor (Start/Stop) Back EMF Protection
- Module Lightning Protection
- Secondary Lightning Protection for AC/DC

## MECHANICAL CHARACTERISTICS

- Approximate Weight: 4 grams
- Lead-Free Silver Plating
- Solder Reflow Temperature: 260-270°C
- Flammability Rating UL 94V-0
- Marking: Logo and Marking Code

## CIRCUIT DIAGRAMS

**Unidirectional****Bidirectional**

## TYPICAL DEVICE CHARACTERISTICS

## RTCA DO-160G COMPLIANT PRODUCT

## MAXIMUM RATINGS @ 25°C Unless Otherwise Specified

PARAMETER	SYMBOL	VALUE	UNITS
Peak Pulse Power (tp = 10/1000µs) - See Figure 1	$P_{PP}$	30,000	Watts
Forward Surge Rating	$I_F$	200	Amps
Steady State Power Dissipation	$P_P$	1.0	Watts
Storage Temperature	$T_{STG}$	-55 to 150	°C
Operating Temperature	$T_L$	-55 to 150	°C

## ELECTRICAL CHARACTERISTICS PER LINE @ 25°C Unless Otherwise Specified

PART NUMBER (Notes 1 - 2)	MARKING CODE		RATED STAND-OFF VOLTAGE $V_{WM}$ VOLTS	BREAKDOWN VOLTAGE		MAXIMUM LEAKAGE CURRENT $@ V_{WM}$ $I_D$ µA	MAXIMUM CLAMPING VOLTAGE (Fig. 2) $@ 10/1000\mu s$ $V_C @ I_{PP}$	TEMPERATURE COEFFICIENT OF $V_{(BR)}$  $qV_{(BR)}$ mV/°C
	UNI	BI		MIN $V_{(BR)}$ VOLTS	$@ I_T$ mA			
SM30KPA28AN	28A	28C	28.0	31.28	50	5000	50.0V @ 606.0A	32
SM30KPA30AN	30A	30C	30.0	33.3	50	5000	55.2V @ 543.0A	34
SM30KPA33AN	33A	33C	33.0	36.7	50	5000	58.6V @ 512.0A	39
SM30KPA36AN	36A	36C	36.0	40.0	50	2000	61.8V @ 485.0A	41
SM30KPA43AN	43A	43C	43.0	47.8	50	1000	73.0V @ 410.0A	50
SM30KPA45AN	45A	45C	45.0	50.3	5	250	77.4V @ 391.5A	51
SM30KPA48AN	48A	48C	48.0	53.3	5	250	77.4V @ 388.0A	56
SM30KPA54AN	54A	54C	54.0	60.0	5	20	91.4V @ 331.5A	64
SM30KPA58AN	58A	58C	58.0	64.4	5	20	92.4V @ 325.0A	68
SM30KPA64AN	64A	64C	64.0	71.1	5	10	104.0V @ 294.0A	76
SM30KPA70AN	70A	70C	70.0	77.8	5	2	109.0V @ 274.0A	83
SM30KPA72AN	72A	72C	72.0	80.4	5	2	114.0V @ 265.0A	85
SM30KPA75AN	75A	75C	75.0	83.3	5	2	119.4V @ 251.0A	89
SM30KPA78AN	78A	78C	78.0	87.1	5	2	129.0V @ 234.9A	92
SM30KPA85AN	85A	85C	85.0	94.4	5	2	139.0V @ 216.0A	105
SM30KPA90AN	90A	90C	90.0	100.0	5	2	147.0V @ 206.0A	109
SM30KPA100AN	100A	100C	100.0	111.0	5	2	162.0V @ 186.0A	121
SM30KPA102AN	102A	102C	102.0	114.0	5	2	166.0V @ 183.0A	124
SM30KPA110AN	110A	110C	110.0	122.0	5	2	178.0V @ 168.0A	126
SM30KPA130AN	130A	130C	130.0	144.0	5	2	209.0V @ 142.0A	157
SM30KPA150AN	150A	150C	150.0	167.7	5	2	233.4V @ 129.8A	195
SM30KPA160AN	160A	160C	160.0	178.0	5	2	252.6V @ 119.0A	195
SM30KPA170AN	170A	170C	170.0	189.0	5	2	274.0V @ 110.0A	207
SM30KPA180AN	180A	180C	180.0	200.0	5	2	291.0V @ 104.0A	230
SM30KPA200AN	200A	200C	200.0	222.0	5	2	320.0V @ 94.0A	250
SM30KPA220AN	220A	220C	220.0	245.0	5	2	356.0V @ 84.0A	269

## TYPICAL DEVICE CHARACTERISTICS

## RTCA DO-160G COMPLIANT PRODUCT

## ELECTRICAL CHARACTERISTICS PER LINE @ 25°C Unless Otherwise Specified

PART NUMBER (Notes 1 - 2)	MARKING CODE		RATED STAND-OFF VOLTAGE  $V_{WM}$ VOLTS	BREAKDOWN VOLTAGE		MAXIMUM LEAKAGE CURRENT  $@V_{WM}$ $I_D$ $\mu A$	MAXIMUM CLAMPING VOLTAGE (Fig. 2)  $@ 10/1000\mu s$ $V_C @ I_{PP}$	TEMPERATURE COEFFICIENT OF $V_{(BR)}$  $qV_{(BR)}$ $mV/^{\circ}C$
	UNI	BI		MIN $V_{(BR)}$ VOLTS	$@I_T$ mA			
SM30KPA250AN	250A	250C	250.0	277.0	5	2	404.0V @ 74.0A	314
SM30KPA260AN	260A	260C	260.0	289.0	5	2	416.0V @ 72.0A	317
SM30KPA280AN	280A	280C	280.0	311.0	5	2	464.0V @ 65.0A	342
SM30KPA300AN	300A	300C	300.0	334.0	5	2	484.0V @ 62.0A	368
SM30KPA320AN	320A	320C	320.0	356.0	5	2	530.0V @ 57.0A	370
SM30KPA360AN	360A	360C	360.0	400.0	5	2	640.0V @ 55.0A	380
SM30KPA480AN	480A	480C	480.0	528.0	5	2	791.0V @ 37.8A	460

## NOTES

- Part numbers shown are unidirectional devices. Add a "C" suffix to specify bidirectional devices, such as SM30KPA20**CAN**.
- $V_{F(MAX)}$  = 15 Volts @ 200A, 8.3ms(1/2 Sine Wave) - *Unidirectional devices only*.

**FIGURE 1**  
PEAK PULSE POWER VS PULSE TIME

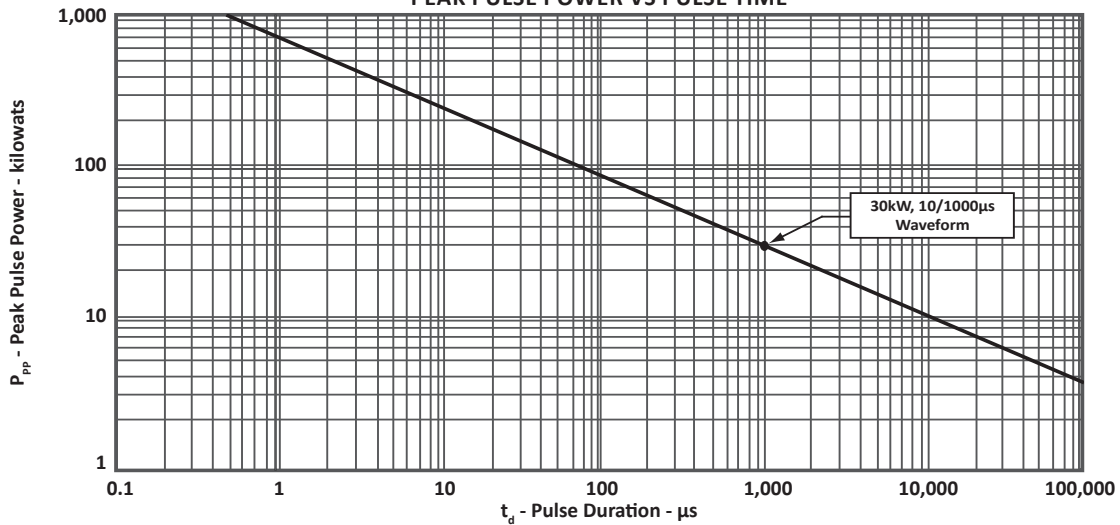

**FIGURE 2**  
PULSE WAVEFORM

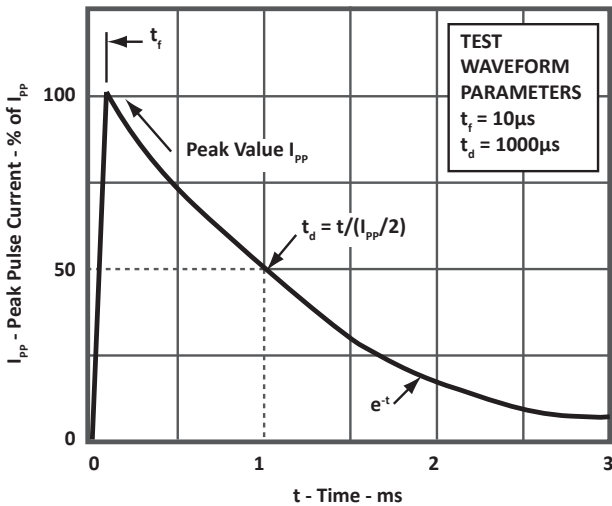

**FIGURE 3**  
POWER DERATING CURVE

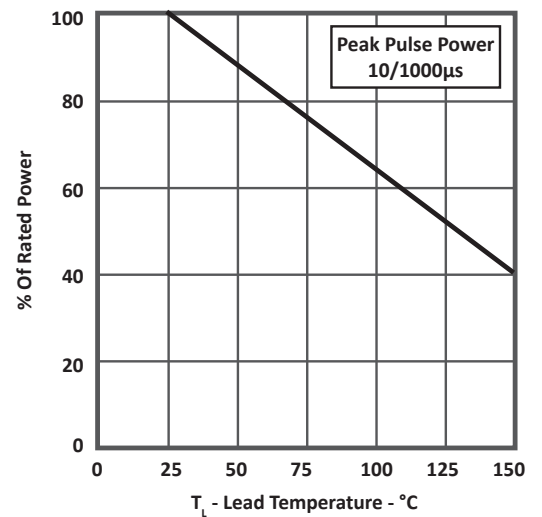

## PACKAGE INFORMATION

## RTCA DO-160G COMPLIANT PRODUCT

## PACKAGE OUTLINE DIMENSIONS

DIM	MILLIMETERS		INCHES	
	MIN	MAX	MIN	MAX
A	7.75	8.26	0.305	0.325
B	11.40	11.50	0.449	0.453
C	1.75	1.85	0.069	0.073
D	2.55	2.79	0.100	0.110
E	13.95	14.45	0.549	0.589
G	0.46	0.56	0.018	0.022
J	4.30	5.45	0.169	0.215
K	15.50	17.02	0.610	0.670
M	0.46	0.56	0.018	0.022
N	5.81	5.97	0.229	0.235

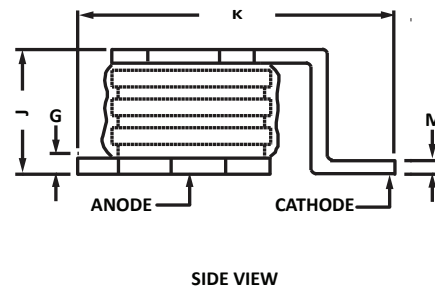
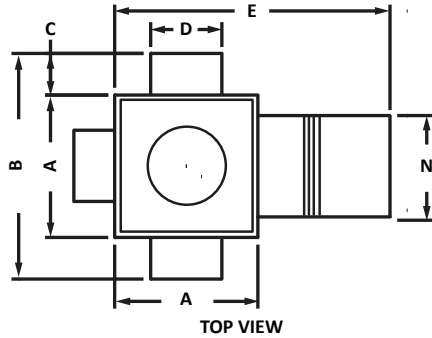

## PACKAGE INFORMATION

## RTCA DO-160G COMPLIANT PRODUCT

## SOLDER PAD OUTLINE DIMENSIONS

DIM	MILLIMETERS		INCHES	
	MIN	MAX	MIN	MAX
A	11.75	11.85	0.462	0.467
B	11.95	12.05	0.470	0.474
C	10.05	10.15	0.396	0.400
D	10.25	10.35	0.403	0.407
E	8.15	8.25	0.321	0.325
F	8.35	8.45	0.329	0.333
G	2.95	3.05	0.116	0.120
H	3.15	3.25	0.124	0.128
J	8.15	8.25	0.321	0.325
K	8.35	8.45	0.329	0.333
L	2.95	3.05	0.116	0.120
M	3.15	3.25	0.124	0.128
N	1.85	1.95	0.073	0.077
P	5.23	5.33	0.206	0.210
Q	6.25	6.35	0.246	0.250
R	6.05	6.15	0.238	0.242
S	1.65	1.75	0.065	0.069
T	5.44	5.54	0.214	0.218
Z	2.55	2.65	0.100	0.104

## SOLDER PRINT OUTLINE DIMENSIONS

DIM	MILLIMETERS		INCHES	
	MIN	MAX	MIN	MAX
A	5.85	5.95	0.230	0.234
B	4.65	5.13	0.183	0.202
C	2.05	2.15	0.081	0.085
D	7.95	8.05	0.313	0.317
E	9.85	9.95	0.388	0.392
F	11.55	11.65	0.455	0.459
G	7.95	8.05	0.313	0.317
H	2.75	2.85	0.108	0.112
J	2.75	2.85	0.108	0.112

Suggested Solder Pad

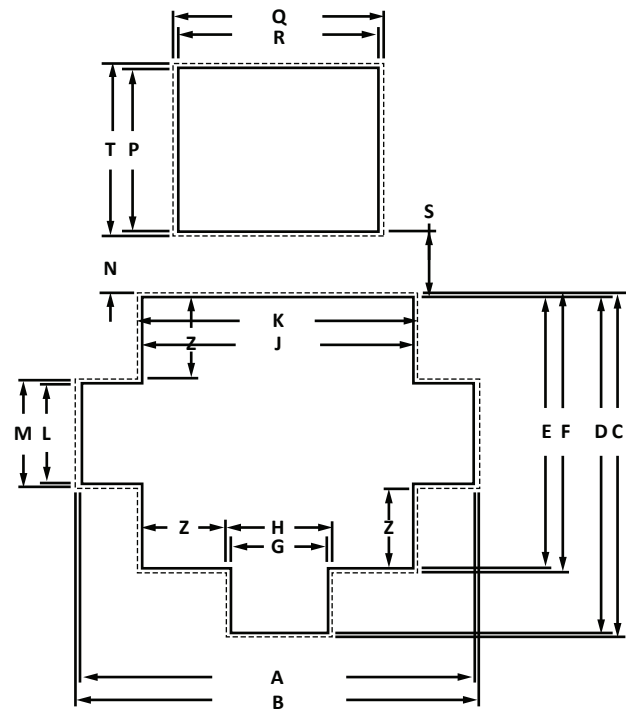

Suggest Solder Print

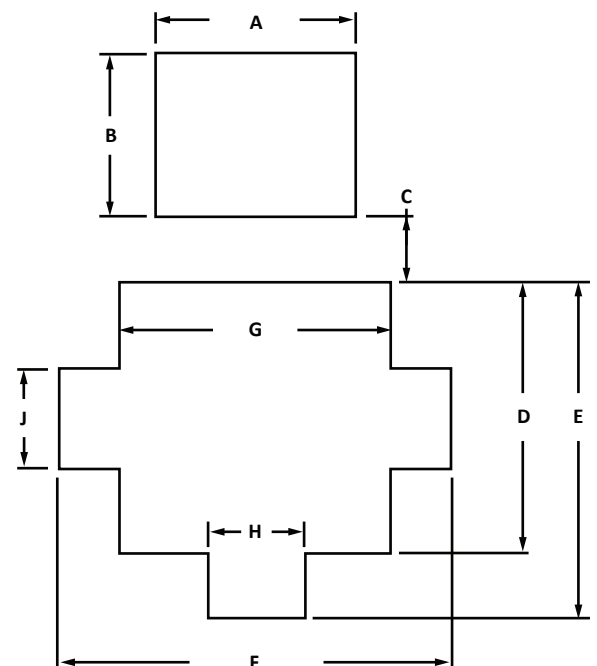

**COMPANY INFORMATION****RTCA DO-160G COMPLIANT PRODUCT****COMPANY PROFILE**

In business more than 20 years, ProTek Devices™ is a privately held semiconductor company. The company offers a product line of overvoltage protection and overcurrent protection components. These include transient voltage suppressor array (TVS arrays) avalanche breakdown diode, steering diode TVS array and electronics SMD chip fuses. These components deliver circuit protection in electronic systems from numerous overvoltage and overcurrent events. They include lightning; electrostatic discharge (ESD); nuclear electromagnetic pulses (NEMP); inductive switching; and electromagnetic interference (EMI) / radio frequency interference (RFI). ProTek Devices also offers high performance interface and linear products. They include analog switches; multiplexers; LED drivers; LED wafer die for ESD protection; audio control ICs; RF and related high frequency products.

**CONTACT US****Corporate Headquarters**

2929 South Fair Lane  
Tempe, Arizona 85282  
USA

**By Telephone**

General: 602-431-8101  
Sales: & Marketing: 602-414-5109  
Customer Service: 602-414-5114  
Product Technical Support: 602-414-5107

**By Fax**

General: 602-431-2288

**By E-mail:**

Asia Sales: [asiasales@protekdevices.com](mailto:asiasales@protekdevices.com)  
Europe Sales: [europesales@protekdevices.com](mailto:europesales@protekdevices.com)  
U.S. Sales: [ussales@protekdevices.com](mailto:ussales@protekdevices.com)  
Distributor Sales: [distysales@protekdevices.com](mailto:distysales@protekdevices.com)  
Customer Service: [service@protekdevices.com](mailto:service@protekdevices.com)  
Technical Support: [support@protekdevices.com](mailto:support@protekdevices.com)

**ProTek Devices (Asia Pacific) Pte. Ltd.**

8 Ubi Road 2, #06-19  
Zervex  
Singapore - 408538  
Tel: +65-67488312  
Fax: +65-67488313

**Web**

[www.protekdevices.com](http://www.protekdevices.com)

COPYRIGHT © ProTek Devices 2014 - This literature is subject to all applicable copyright laws and is not for resale in any manner.

SPECIFICATIONS: ProTek reserves the right to change the electrical and or mechanical characteristics described herein without notice.

DESIGN CHANGES: ProTek reserves the right to discontinue product lines without notice and that the final judgement concerning selection and specifications is the buyer's and that in furnishing engineering and technical assistance. ProTek assumes no responsibility with respect to the selection or specifications of such products. ProTek makes no warranty, representation or guarantee regarding the suitability of its products for any particular purpose, nor does ProTek assume any liability arising out of the application or use of any product or circuit and specifically disclaims any and all liability without limitation special, consequential or incidental damages.

LIFE SUPPORT POLICY: ProTek Devices products are not authorized for use in life support systems without written consent from the factory.